

nominal specifications	
3/2-way coaxial valve	externally controlled
pressure range	0-600 psi
connection	thread
function	NC - normally closed, flow A ⇒ C NO - normally open, flow A ⇒ B
design	pressure balanced, with spring return
body materials parts in contact with media	brass
seal materials seat / dynamic / static	PTFE / FPM / FPM customer to verify seal / seat compatibility with media
media	gaseous - liquid - highly viscous - gelatinous - contaminated
actuator connection	FNPT 1/8 with NAMUR pilot valve interface

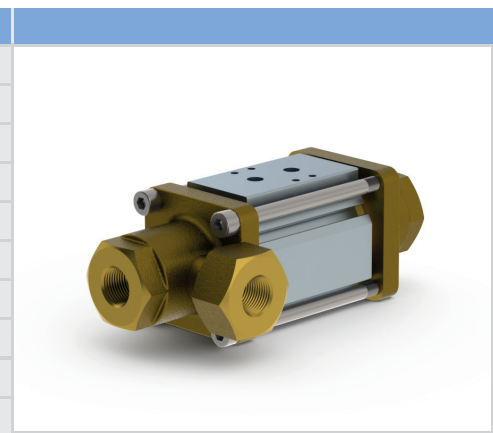

technical data	CXF 10 DR	CXF 15 DR	CXF 20 DR	CXF 25 DR
orifice	DN 10	DN 15	DN 20	DN 25
threads	FNPT 3/8	FNPT 1/2	FNPT 3/4	FNPT 1
Cv A ⇒ B / A ⇒ C	2.5 / 2.2	6.1 / 4.5	10.8 / 7.7	15.0 / 12.7
media temperature	-4 °F to +212 °F	-4 °F to +212 °F	-4 °F to +212 °F	-4 °F to +212 °F
ambient temperature	-4 °F to +140 °F	-4 °F to +140 °F	-4 °F to +140 °F	-4 °F to +140 °F
pneumatic actuation	pilot valve optional	pilot valve optional	pilot valve optional	pilot valve optional
actuation pressure	60-120 psi	60-120 psi	60-120 psi	60-120 psi
switching time opening: 60 psi actuation pressure	120 ms to 3000 ms	140 ms to 3000 ms	160 ms to 3000 ms	200 ms to 3000 ms
switching time closing: 60 psi actuation pressure	200 ms to 3000 ms	240 ms to 3000 ms	240 ms to 3000 ms	280 ms to 3000 ms
vacuum leak rate	< 10 ⁻⁴ mbar•les ⁻¹	< 10 ⁻⁴ mbar•les ⁻¹	< 10 ⁻⁴ mbar•les ⁻¹	< 10 ⁻⁴ mbar•les ⁻¹
flow direction	A ⇒ B / A ⇒ C B ⇒ A	A ⇒ B / A ⇒ C B ⇒ A	A ⇒ B / A ⇒ C B ⇒ A	A ⇒ B / A ⇒ C B ⇒ A
length L1 / L2	6.45 in / 1.97 in	7.87 in / 2.76 in	9.02 in / 3.15 in	9.80 in / 3.54 in
length L3 / L4	1.46 in / 1.26 in	2.36 in / 1.52 in	2.83 in / 1.79 in	3.15 in / 1.89 in
weight without pilot valve	3.31 lb	6.61 lb	9.70 lb	13.45 lb

accessories optional	order-codes			
5/2 way pilot valve NAMUR DC 24 V	1 2 3 7 4 7	1 2 3 7 4 7	1 2 3 7 4 7	1 2 3 7 4 7
5/2 way pilot valve NAMUR AC 110 V	1 2 3 7 4 8	1 2 3 7 4 8	1 2 3 7 4 8	1 2 3 7 4 8
mounting brackets stainless steel	1 2 3 5 5 5	1 2 3 5 5 6	1 2 3 5 5 7	1 2 3 5 5 8
limit switch REED (AC/DC 10-30 V)	1 2 3 5 5 4	1 2 3 5 5 4	1 2 3 5 5 4	1 2 3 5 5 4

drawings	circuit symbols	valve order-code
	<p>function: NC closed when not energized</p> <p>function: NO open when not energized</p>	<p>9 8 3 1</p> <p>NC = 7 NO = 8</p> <p>DN 10 = 5 DN 15 = 6 DN 20 = 7 DN 25 = 8</p>